



# LV-Link A

## USER MANUAL

# Contents

Statement of Law .....	1
Revision History .....	1
Safety Precautions .....	2
Preface .....	3
Manual declaration .....	3
1 Introduction .....	4
Brief Introduction .....	4
Product Properties .....	4
Product Identity Definition .....	5
2 Product Specification .....	6
Size and Weight .....	6
Performance Parameter .....	6
Interface Definition .....	6
Product parameters .....	11
3 Installation and Configuration .....	12
Preparation for installation .....	12

## Statement of Law

Copyright of this document belongs to DyNESS Digital Energy Technology Co., LTD. No part of this documentation maybe excerpted, reproduced, translated, annotated or duplicated in any form or by any means without the prior written permission of DyNESS Digital Energy Technology Co., LTD. All Rights Reserved.

This product complies with the design requirements of environmental protection and personal safety. The storage, use and disposal of the products shall be carried out in accordance with the product manual, relevant contract or relevant laws and regulations.

Customer can check the related information on the website of DyNESS Digital Energy Technology Co., LTD. when the product or technology is updated.

Web URL: <http://www.dyNESS.com/>

Please note that the product can be modified without prior notice.

## Revision History

Revision NO.	Revision Date	Revision Reason
1.0	2024.03.29	First Published

## Safety Precautions



### WARNING

Please do not put the LV-Link into water or fire, in case of explosion or any other situation that might endanger your life.

Please connect wires properly while installation, do not reverse connect.

To avoid short circuit, please do not connect positive and negative poles with conductor on the same device.

Please avoid any form of damage to battery, especially stab, hit, trample or strike.

Please shut off the power completely when removing the device or reconnecting wires during the daily use or it could cause the danger of electric shock.

Please use dry powder extinguisher to put out the flame when encountering a fire hazard, liquid extinguisher could result in the risk of explosion.

For your safety, please do not arbitrarily dismantle any component in any circumstances.

The maintenance must be implemented by authorized technical personnel or our company's technical support. Device breakdown due to unauthorized operation will not be covered under warranty.



### CAUTION

Our products have been strictly inspected before shipment. Please contact us if you find any abnormal phenomena such as device outer case bulging.

To assure the proper use please make sure parameters among the relevant device are compatible and matched.

Ambient and storage method could impact the product life span, please comply with the operation environment instruction to ensure device works in proper condition.

## Preface

### Manual declaration

LV-Link can flexibly expand different versions of Dy Ness PowerBox Pro and PowerDepot H5B. Provide energy storage for photovoltaic power generation users through parallel combination. Our product can store extra electricity into battery from photovoltaic power generation system in daytime and supply stable power to user's equipment as power backup at nighttime or any time when needed. It can improve the efficiency of photovoltaic power generation and increase the electric power efficiency by peak load shifting.

This user manual details the basic structure, parameters, basic procedures and methods of installation and operation and maintenance of the equipment.

# 1 Introduction

## Brief Introduction

LV-Link is a standard system communication box that allows different versions of Dy Ness PowerBox Pro and Power Depot H5B to be flexibly connected in parallel to form a larger capacity battery pack to meet the long-term power supply needs of users. The product is especially suitable for energy storage applications with high operating temperature, limited installation space, long backup time and long service life.

## Product Properties

LV-Link uses TI, GD and other special chips to enhance product durability and better performance. The system features are as follows:

- Comply with European ROHS, CE certification, employ non-toxic, non-pollution environment-friendly PCB.
- Carries battery management system with better performance, possesses protection function like over-discharge, over-charge, over-current, abnormal temperature.
- Self-management on charging and discharging.
- Intelligent design configures integrated inspection module.
- Flexible configurations allow parallel of multi battery for longer standby time.
- Self-ventilation with lower system noise.
- With wide range of temperature for working environment,  $-20^{\circ}\text{C} \sim +55^{\circ}\text{C}$ , circulation span and discharging performance are well under high temperature.
- Less volume, lighter weight.

## Product Identity Definition

Table 1-1 Symbol Definition

	Battery voltage is higher than safe voltage, direct contact with electric shock hazard.
	flammable.
	Read the user manual before using.
	The scrapped battery cannot be put into the garbage can and must be professionally recycled.
	After the battery life is terminated, the battery can continue to be used after it recycled by the professional recycling organization and do not discard it at will.
	Do not place near open flame or incinerate.
	If catch fire, do not put out with water.
	If catch fire, do not put out with dry powder fire extinguisher.
	Do not cut or spear with sharp objects.
	This battery product meets European directive requirements.

## 2 Product Specification

### Size and Weight

Table 2-1 LV-Link A Device size

Product	Nominal Voltage	Dimension	Weight
LV-Link A	DC51.2V	135×82×36mm	1.5kg

### Performance Parameter

Table 2-2 LV-Link A performance parameter

Item	Parameter value
Nominal Voltage(V)	51.2
Work Voltage Range(V)	42~60

### Interface Definition

This section elaborates the interface functions of the front interface of the device.

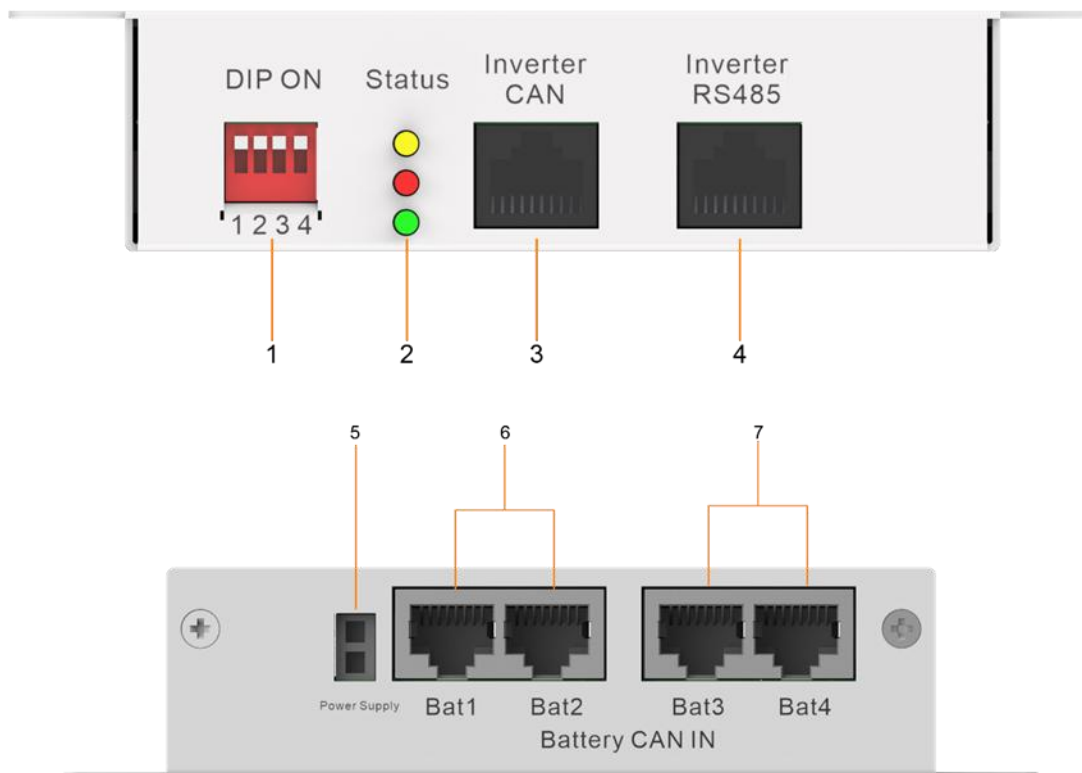

Figure 2-1 The Sketch of Interface



Table 2-3 Interface Definition

Item	Name	Definition
1	DIP Switch	Master communication protocol and baud rate selection. Table 2-1 for details.
2	Status	The green light is always on for normal. The red light is always on or flashing to indicate an alarm. The flashing yellow light indicates communication disconnection between the battery and the LV-Link A. If the green indicator blinks, the DIP Switch of LV-Link A is not turned.
3	Inverter CAN	Communicates with the COM port of the inverter
4	Inverter RS485	Communicates with the COM port of the inverter
5	Power Supply	The interface is used to power the LV-Link A
6	Battery 1 CAN IN	Communicates with the COM port of the Battery1
7	Battery 2 CAN IN	Communicates with the COM port of the Battery2

Table 2-4 DIP switch definition and description

DIP switch position (master communication protocol and baud rate selection)			
#1	#2	#3	#4
			Baud rate selection
Define different protocols; Distinguish between master and slave			OFF: CAN: 500K,485: 9600 ON: CAN: 250K,485: 115200

**DIP Switch Description**

When the batteries are connected in parallel, the master communicates with the slaves through the CAN interface. LV-Link summarizes the information of the entire battery system and communicates with the inverter through CAN or 485.

If the master is the LV-Link with DIP switch:

1. The communication cable from LV-Link CAN IN to the inverter comm port should be the correct one.

DIP Switch Description

2. When the battery works with GOODWE, Solis, LUX, Sofar, DEYE(Sunsynk), VICTRON, IMEON, Sungrow, SMA, RENAC, DELIOS, SAJ(CAN Comm) before starting the battery, you need to put LV-Link DIP switch "# 3" to the "ON" position (to the top), then turn on the batteries.

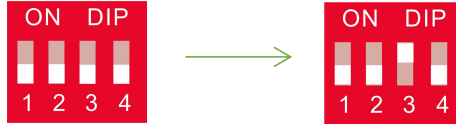

LV-Link Setting 1

3. If the battery communicates with the Axpert-king/VMIII/MAX, Infinisolar, Growatt SPH/SPA(CAN comm) GMDE, turn the LV-Link DIP switch "#2" to "ON" position.

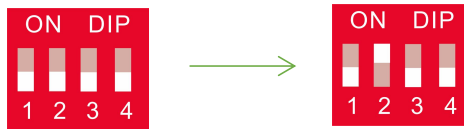

LV-Link Setting 2

4. If the battery communicates with the Growatt SPF HVM-P/ES/WPV by RS485 communication, turn the LV-Link DIP switch "#2" and "#3" to "ON".

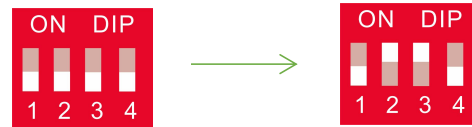

LV-Link Setting 3

5. If the battery communicates with the Schneider Conext Series, turn the LV-Link DIP switch "#1" and "#3" to "ON".

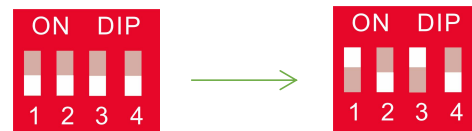

LV-Link Setting 4

6. When you setup the LV-Link DIP as setting 1~4, all the PowerBox Pro or PowerDepot H5B keep the DIP 0010, no need to change.

Note: For more information of matching inverter brands, please subject to the latest document

<The list of compatibility between Dyness ESS and Inverters >.

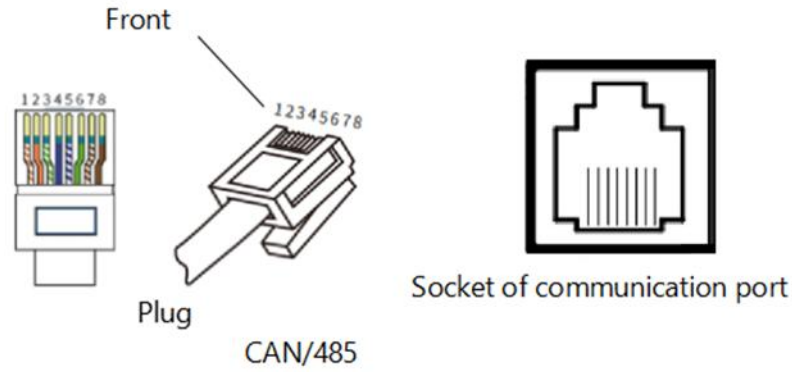

Figure 2-2 CAN/485 Interface Definition

Table 2-5 Inverter CAN Interface Definition

Foot position	Color	Definition
PIN1	Orange/white	Reserve
PIN2	Orange	Reserve
PIN3	Green/white	Reserve
PIN4	Blue	Inverter CANH
PIN5	Blue/white	Inverter CANL
PIN6	Green	Reserve
PIN7	Brown/white	Reserve

Figure 2-6 Inverter RS485 Interface Definition

Foot position	Color	Definition
PIN1	Orange/white	485B
PIN2	Orange	485A
PIN3	Green/white	Reserve
PIN4	Blue	Reserve
PIN5	Blue/white	5V
PIN6	Green	TX
PIN7	Brown/white	RX
PIN8	Brown	GND

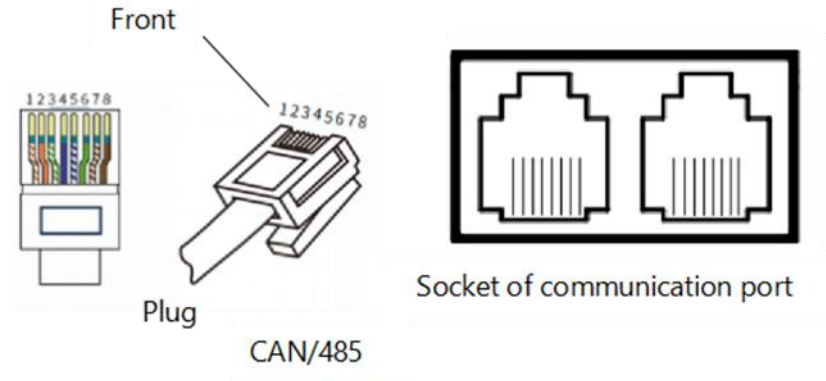

Battery 1 CAN Interface Definition

Foot position	Color	Definition
PIN1	Orange/white	Reserve
PIN2	Orange	Reserve
PIN3	Green/white	Reserve
PIN4	Blue	CAN1H
PIN5	Blue/white	CAN1L
PIN6	Green	Reserve
PIN7	Brown/white	Reserve
PIN8	Brown	Reserve
PIN9	Orange/white	Reserve
PIN10	Orange	Reserve
PIN11	Green/white	Reserve
PIN12	Blue	CAN1H
PIN13	Blue/white	CAN1L
PIN14	Green	Reserve
PIN15	Brown/white	Reserve
PIN16	Brown	Reserve

## Battery 2 CAN Interface Definition

Foot position	Color	Definition
PIN1	Orange/white	Reserve
PIN2	Orange	Reserve
PIN3	Green/white	Reserve
PIN4	Blue	CAN2H
PIN5	Blue/white	CAN2L
PIN6	Green	Reserve
PIN7	Brown/white	Reserve
PIN8	Brown	Reserve
PIN9	Orange/white	Reserve
PIN10	Orange	Reserve
PIN11	Green/white	Reserve
PIN12	Blue	CAN2H
PIN13	Blue/white	CAN2L
PIN14	Green	Reserve
PIN15	Brown/white	Reserve
PIN16	Brown	Reserve

Tips: Please pay attention of the communication com definition of inverter, in order to avoid voltage in the port to affect communication.

### Product parameters

- Operating voltage: 42V~60V
- Operating temperature: -20°C ~ + 55°C
- Storage temperature: -10°C ~+35°C
- Relative humidity: 5% ~ 85%RH
- Elevation: no more than 4000m

### 3 Installation and Configuration

#### Preparation for installation

##### Safety Requirement

This system can only be installed by personnel who have been trained in the power supply system and have sufficient knowledge of the power system.

The safety regulations and local safety regulations listed below should always be followed during the installation.

- All circuits connected to this power system with an external voltage of less than 51.2V must meet the SELV requirements defined in the IEC60950 standard.
- If operating within the power system cabinet, make sure the power system is not charged. Battery devices should also be switched off.
- Distribution cable wiring should be reasonable and has the protective measures to avoid touching these cables while operating power equipment.
- The following protective items must be worn when installing the battery system:



Insulated Gloves



Safety Goggles



Safety Shoes

Figure 3-1 Safety Gear

##### Environmental requirements

Working temperature: -20°C ~+55°C

Charging temperature range is 0°C~+55°C,

Discharging temperature range is -20°C ~+55°C

Storage temperature: -10°C~+35°C

Relative humidity: 5% ~ 85%RH

Elevation: no more than 4000m

Operating environment: Indoor installation, sites avoid the sun and no wind, no conductive dust and corrosive gas.

And the following conditions are met:

- Installation location should be away from the sea to avoid brine and high humidity environment.
- The ground for product arrangement shall be flat and level.
- No flammable explosive materials near the installation site.
- The optimal ambient temperature is 15°C~30°C
- Keep away from dust and messy zones

## Tools and data

Tools and meters that may be used are shown in Figure 3-2 Installation Tools.

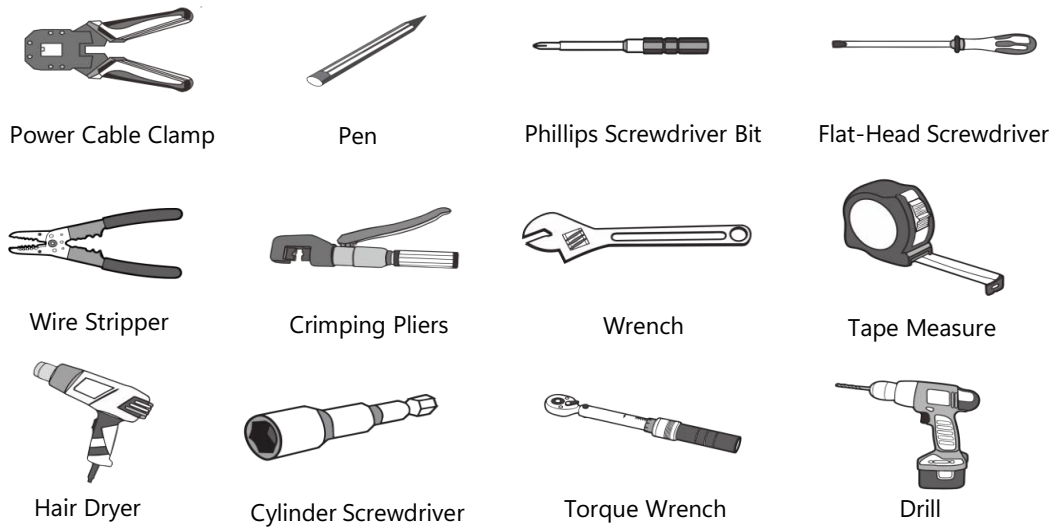

Figure 3-2 Installation Tools

## Technical preparation

### Electrical interface check

Devices that can be connected directly to the battery can be user equipment, power supplies, or other power supplies.

- Confirm whether the user's PV power generation equipment, power supply or other power supply equipment has a DC output interface, and measure whether the DC power output voltage meets the voltage range requirements in Table 2-2.
- Confirm that the maximum discharge current capability of the DC power interface of the user's photovoltaic power generation equipment, power supply or other power supply equipment should be less than the maximum charging current of the Batteries.
- If the maximum discharge capability of the DC power interface of the user's photovoltaic power generation equipment is higher than the maximum charging current of the Batteries, the DC power interface of the user's photovoltaic power generation equipment shall have a current limiting function to ensure the normal operation of the user's equipment.
- Verify that the maximum operating current of the battery-powered user equipment (inverter DC input) should be less than the maximum discharge current of the Batteries.





### The security check

- Firefighting equipment should be provided near the product, such as portable dry powder fire extinguisher.
- Automatic fire fighting system shall be provided for the case where necessary.
- No flammable, explosive and other dangerous materials are placed beside the battery.

### Unpacking Inspection

- When the equipment arrives at the installation site, loading and unloading should be carried out according to the rules and regulations, to prevent from being exposed to sun and rain.
- Before unpacking, the total number of packages shall be indicated according to the shipping list attached to each package, and the case shall be checked for good condition.
- In the process of unpacking, handle with care and protect the surface coating of the object.
- Open the package, the installation personnel should read the technical documents, verify the list, according to the configuration table and packing list, ensure objects are complete and intact, if the internal packing is damaged, should be examined and recorded in detail.

Table 3-3 Packing List

Item	Specification	Quantity	Figure
LV-Link	LV-Link A	1	
Power supply cable	Red /4AWG/L250mm	1	
Communication cable-to inverter	Black /L2000mm /Double RJ45 plug	1	
User Manual	User manual	1	
Expansion screw	Expansion screw	2	

### Engineering coordination

- Attention should be paid to the following items before construction:

Power line specification.

- The power line specification shall meet the requirements of maximum discharge current for each product.

Mounting space and bearing capacity.

- Make sure that the battery has enough room to install, and that the brackets have enough load capacity.

Wiring.

- Make sure the power line and ground wire are reasonable. Not easy to short-circuit, water and corrosion.



## Installation Preparation

1. Prepare equipment and tools for installation.
2. Check the LV-Link unit and confirm that the device is turned off.

## Mechanical Installation

### Wall hanging Installation method:

1. Make the LV-Link parallel to the ground using a horizontal measuring instrument. Mark the screw holes on the wall using the two holes of the LV-Link, and drill the holes, as shown in Figure 3-4. Use an electric drill to drill two holes with a diameter of 10mm and a depth greater than 70mm on the wall to install M6 expansion bolts.

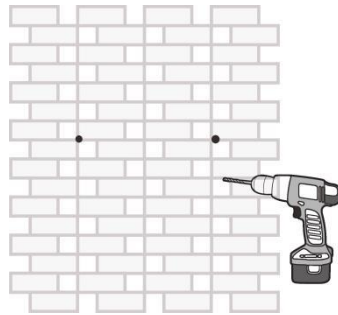
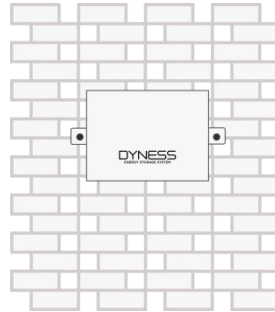

Figure 3-4

2. According to the position of the mark, 2 holes in diameter 10mm and depth of more than 70mm are hit on the wall with an electric drill, which are used for fitting expansion bolt M6.



## Electrical installation

Before connecting the power cables, use multimeter to measure cable continuity, short circuit, confirm positive and negative, and accurately mark the cable labels.

Measuring methods:

Power cable check: select the buzzer mode of multimeter and detect the both ends of the same color cable. If the buzzer calls, it means the cable is in good condition.

Short circuit judgment: choose multimeter resistor file, probe the same end of positive and negative pole, if the resistor shows infinity, means that the cable is available.

After visual testing of power line connection, the positive and negative poles of the battery shall be connected respectively to the positive and negative poles of the opposite terminal.

It is better to add a circuit breaker between the inverter and the battery system. The selection of the circuit breaker requires:

Voltage:  $U > 60V$

Current:  $I = \text{Inverter power} / 45V$

The circuit breaker is installed between the battery module and the inverter, as shown in Figure 3-5:

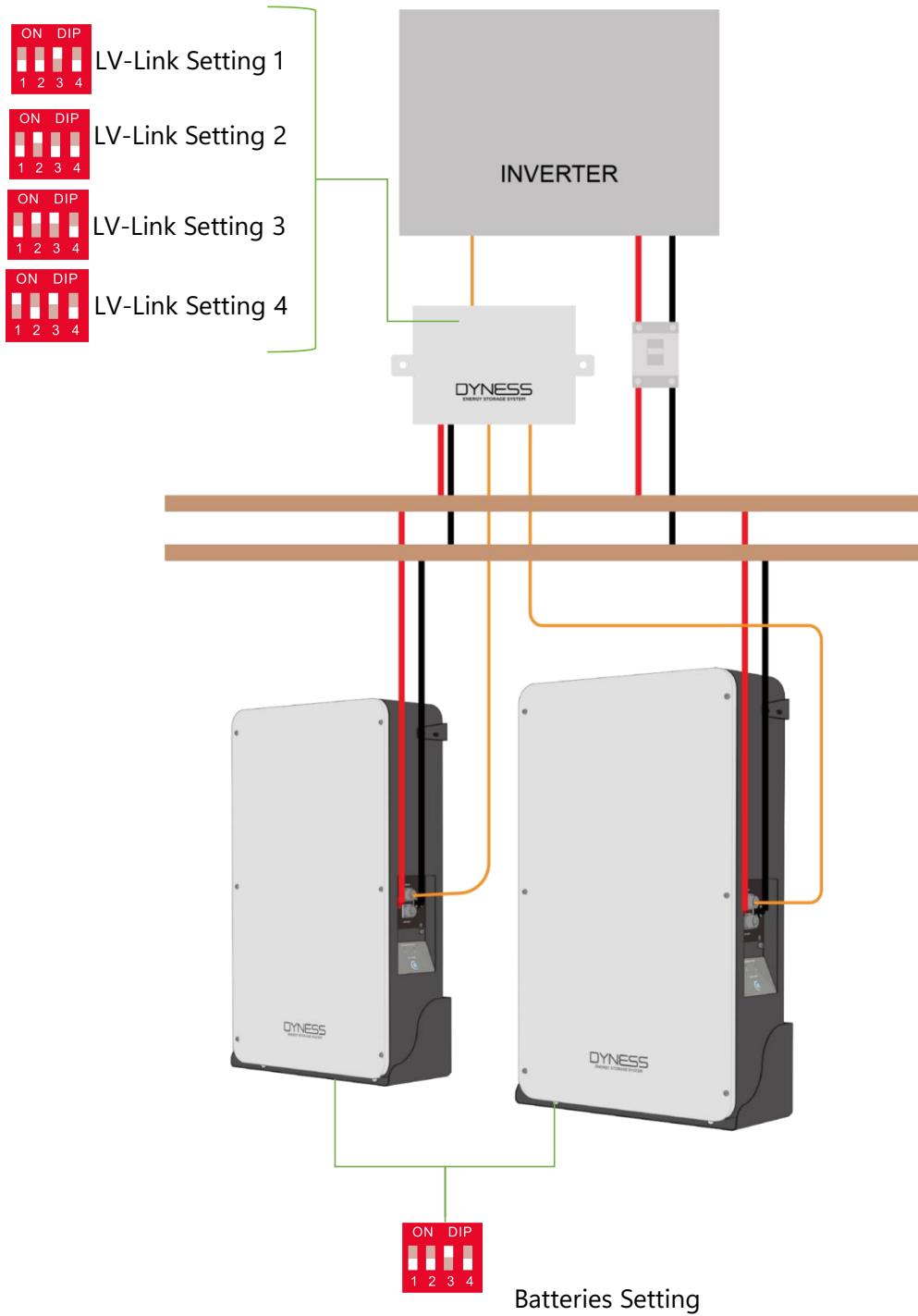

Figure 3-5

**Note:**

1. For more ADD Settings, please refer to P7 "DIP switch definition and description"
2. After the whole system connection, set the master DIP mode according to the inverter model firstly, then start the battery.
3. The BAT-INV comms cable is from inverter comm port to LV-Link Inverter CAN port, BAT-BAT comms cable is from BAT1 CAN IN to LV-Link BAT1 CAN, BAT2 CAN IN to LV-Link BAT2 CAN
4. The limited continuous current for each pair of power cable is 120A. Please add power cable according to the proportion if the max working current of the inverter is more than 120A.

**Register on the website after installation**

After the battery system installation is completed and the running is normal, you need to log in to the DYNESS official website to register the product installation and use information to make the product warranty effective. Please follow the instructions on the website to register.

<http://www.dyNESS.com/>  Service  Sign Up



DISCOVER YOUR NATURE

Address: No. 511 Chenzhuang West Road, Sanshui Street,  
Jiangyan District, Taizhou City

Email: [service@dyness-tech.com](mailto:service@dyness-tech.com)

Tel: +86 400 666 0655

Web: [www.dyness.com](http://www.dyness.com)



Official Website



Digital version access